

DATA SHEET



SAA7715AH Digital Signal Processor

Preliminary specification

2003 Mar 13

Digital Signal Processor

SAA7715AH

1 FEATURES

1.1 Hardware

- 24-bit Philips 70 MIPS DSP core (24-bit data path and 12/24-bit coefficient path)
- 1.5 kbyte of downloadable DSP program memory (PRAM)
- 2 kbyte of DSP program memory (PROM)
- 2.875 kbyte of re-programmable DSP data memory (XRAM)
- 1.5 kbyte of re-programmable DSP coefficient memory (YRAM)
- Four stereo digital serial inputs (8 channels) with common BCK and WS. To these inputs the I²S-bus format or LSB-justified formats can be applied
- One stereo bitstream DAC (2 channels) with 64 fold oversampling and noise shaping
- Selectable clock output (pin SYSCLOCK) for external slave devices (128f_s to 512f_s)
- Four stereo digital serial outputs (8 channels) with selectable I²S-bus or LSB-justified format
- Two SPDIF inputs combined with digital serial input
- On-board WS_PLL generates clock for on-board DAC and output pin SYSCLOCK
- I²C-bus controlled (including fast mode)
- Programmable Phase-Locked Loop (PLL) derives the clock for the DSP from the CLK_IN input
- -40 to +85 °C operating temperature range
- Supply voltage only 3.3 V
- All digital inputs are tolerant for 5 V input levels
- Power-down mode for low current consumption in standby mode
- Optimized pinning for applications with other Philips DACs (such as UDA1334, UDA1355 and UDA1328).

1.2 Possible firmware

- Dolby®⁽¹⁾ Pro Logic decoding
- Smoothed volume control (without zipper noise)
- Automatic Volume Levelling (AVL)
- Dynamic bass enhancement
- Ultra bass

(1) **Dolby** — Available only to licensees of Dolby Laboratories Licensing Corporation, San Francisco, CA94111, USA, from whom licensing and application information must be obtained. Dolby is a registered trade-mark of Dolby Laboratories Licensing Corporation.



- Incredible surround
- Incredible mono (Imono)
- DPL virtualizer
- Dolby digital virtualizer (DVD post-processing)
- Dynamic compressor
- Spectral enhancer
- Equalizer with peaking/shelving filters
- DC filters
- Bass/treble control
- Dynamic loudness
- Tone/noise generator
- Graphical spectrum analyser
- Configurable Delay Unit (DLU)
- Sound steering/elevation for car applications
- Sample Rate Conversion (SRC).

2 APPLICATIONS

- As co-processor for a car radio DSP in a car radio application for additional acoustic enhancements (sound steering/sound elevation/signal processing)
- Multichannel audio: in DVD and Home theatre applications as post-processing device such as signal virtualization (virtual 3D surround) and acoustic enhancement, tone control, volume control and equalizers
- Multichannel decoding: Dolby Pro Logic and virtual 3D surround
- PC/USB audio applications: stereo widening (Incredible surround), sound steering, sound positioning and speaker equalization.

Digital Signal Processor

SAA7715AH

3 GENERAL DESCRIPTION

The SAA7715AH is a cost effective and powerful high performance 24-bit programmable DSP for a variety of digital audio applications. This DSP device integrates a 24-bit DSP core with programmable memories (program RAM/ROM, data and coefficient RAM), 4 digital serial inputs, 4 digital serial outputs, 2 separate SPDIF receivers, a stereo FSDAC, a standard Philips I²C-bus interface, a phase-locked loop for the DSP clock generation and a second phase-locked loop for system clock generation (internal and external DAC clocks).

The SAA7715AH can be configured for various audio applications by downloading the dedicated DSP program code into the DSP program RAM or using the ROM or a combination of both. During the Power-down mode the contents of the memories and all other settings will keep their values. The SAA7715AH can be initialized using the I²C-bus interface.

Several system application examples, based on this existing SAA7715AH, are available for a wide range of audio applications (e.g car radio DSP, DVD post-processing, Dolby Pro Logic, PC/USB audio and more) which can be used as a reference design for customers.

4 QUICK REFERENCE DATA

SYMBOL	PARAMETER	CONDITIONS	MIN.	TYP.	MAX.	UNIT
V _{DD}	operating supply voltage	all pins V _{DD} with respect to pins V _{SS}	3.15	3.3	3.45	V
I _{DDD}	supply current of the digital part	high activity of the DSP at DSPFREQ frequency	–	95	–	mA
I _{DDA}	supply current of the analog part	zero input and output signal	–	20	–	mA
P _{tot}	total power dissipation	high activity of the DSP at DSPFREQ frequency	–	380	–	mW
I _{POWERDOWN}	DC supply current of the total chip in Power-down mode	pin POWERDOWN enabled	–	400	–	μA
f _s	sample frequency	at IIS_WS1, SPDIF1 or SPDIF2 input	32	44.1	96	kHz
(THD + N)/S _{DAC}	total harmonic distortion-plus-noise to signal ratio of DAC	at 0 dB	–	–85	–	dB(A)
		at –60 dB	–	–37	–	dB(A)
S/N _{DAC}	signal-to-noise ratio of DAC	code = 0	–	100	–	dB(A)
f _{CLK_IN}	clock input frequency	DIV_CLK_IN = LOW	8.192	11.2896	12.288	MHz
		DIV_CLK_IN = HIGH	16.384	–	24.576	MHz
DSPFREQ	maximum DSP clock frequency		–	–	70	MHz

5 ORDERING INFORMATION

TYPE NUMBER	PACKAGE		
	NAME	DESCRIPTION	VERSION
SAA7715AH	QFP44	plastic quad flat package; 44 leads (lead length 1.3 mm); body 10 × 10 × 1.75 mm	SOT307-2

Digital Signal Processor

SAA7715AH

6 BLOCK DIAGRAM

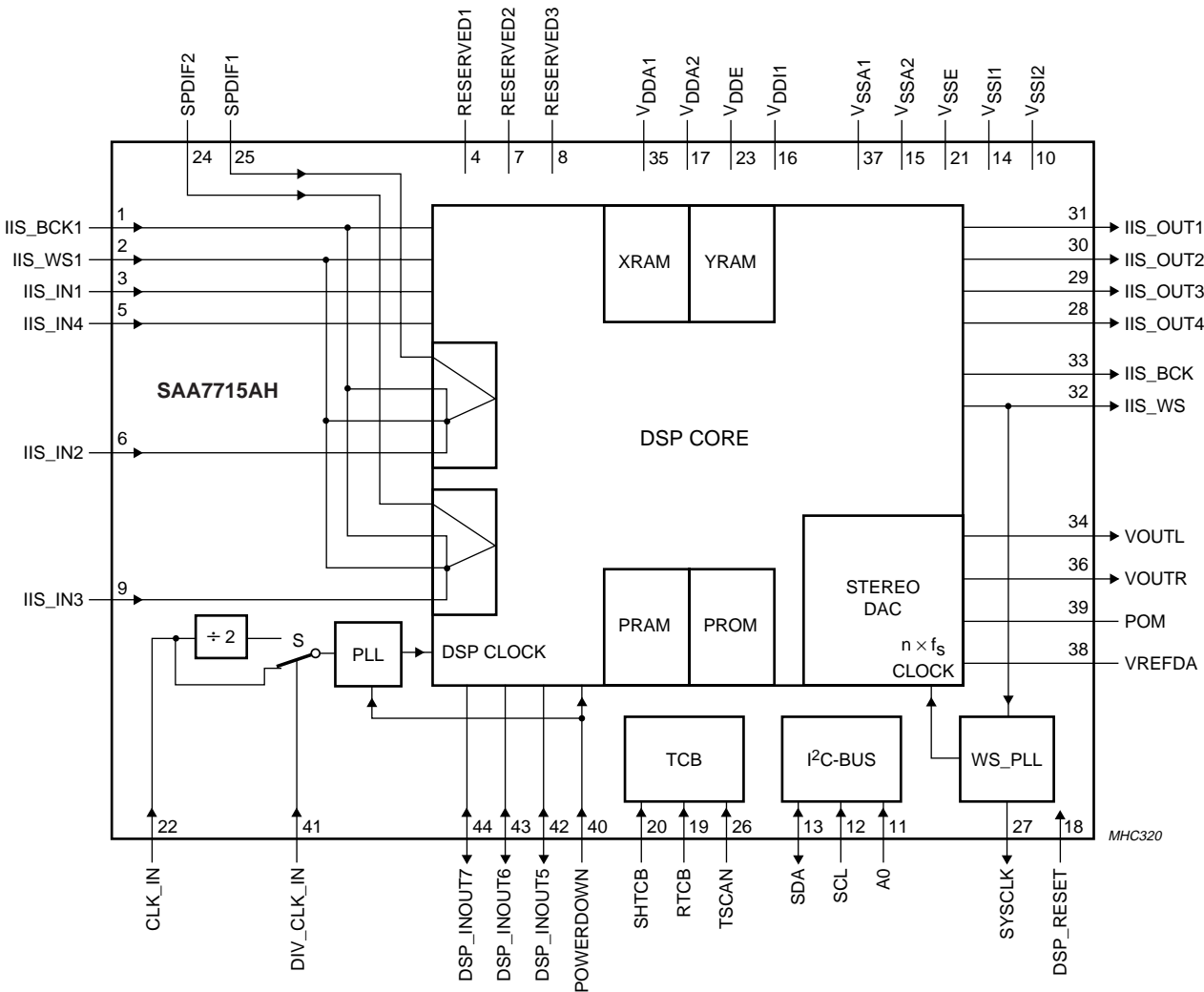

Fig.1 Block diagram.

Digital Signal Processor

SAA7715AH

7 PINNING

SYMBOL	PIN	PIN TYPE	DESCRIPTION
IIS_BCK1	1	ipthdt5v	bit clock signal belonging to data of digital serial inputs 1 to 4
IIS_WS1	2	ipthdt5v	word select signal belonging to data of digital serial inputs 1 to 4
IIS_IN1	3	ipthdt5v	data pin of digital serial input 1
RESERVED1	4	ipthdt5v	not to be connected externally
IIS_IN4	5	ipthdt5v	data pin of digital serial input 4
IIS_IN2	6	ipthdt5v	data pin of digital serial input 2
RESERVED2	7	ipthdt5v	not to be connected externally
RESERVED3	8	ipthdt5v	not to be connected externally
IIS_IN3	9	ipthdt5v	data pin of digital serial input 3
V _{SSI2}	10	vssi	ground supply (core only) (bond out to 2 pads)
A0	11	ipthdt5v	slave sub-address I ² C-bus selection/serial data input test control block
SCL	12	iptht5v	clock input of I ² C-bus
SDA	13	iic400kt5v	data input/output of I ² C-bus
V _{SSI1}	14	vssis	ground supply (core only)
V _{SSA2}	15	vssco	ground supply analog of PLL, WS_PLL, SPDIF input stage
V _{DDI1}	16	vddi	positive supply (core only) (bond out to 2 pads)
V _{DDA2}	17	vddco	positive supply analog of PLL, WS_PLL, SPDIF input stage
DSP_RESET	18	ipthut5v	general reset of chip (active LOW)
RTCB	19	ipthdt5v	asynchronous reset test control block, connect to ground (internal pull down)
SHTCB	20	ipthdt5v	shift clock test control block (internal pull down)
V _{SSE}	21	vsse	ground supply (peripheral cells only)
CLK_IN	22	iptht5v	system clock input
V _{DDE}	23	vdde	positive supply (peripheral cells only)
SPDIF2	24	apio	SPDIF2 data input (internally multiplexed with digital serial input 3)
SPDIF1	25	apio	SPDIF1 data input (internally multiplexed with digital serial input 2)
TSCAN	26	ipthdt5v	scan control active HIGH (internal pull down)
SYSCLK	27	bpt4mthdt5v	$n \times f_s$ output of SAA7715AH
IIS_OUT4	28	ops5c	data pin of digital serial output 4
IIS_OUT3	29	ops5c	data pin of digital serial output 3
IIS_OUT2	30	ops5c	data pin of digital serial output 2
IIS_OUT1	31	ops5c	data pin of digital serial output 1
IIS_WS	32	ops5c	word select output belonging to digital serial output 1 to 4
IIS_BCK	33	ops5c	bit clock output belonging to digital serial output 1 to 4
VOU _{TL}	34	apio	analog left output pin.
V _{DDA1}	35	vddo	FSDAC positive supply voltage (bond out to 2 pads)
VOU _{TR}	36	apio	analog right output pin
V _{SSA1}	37	vsso	FSDAC ground supply voltage (bond out to 2 pads)
VREFDA	38	apio	voltage reference pin of FSDAC
POM	39	apio	power-on mute pin of FSDAC
POWERDOWN	40	iptht5v	standby mode of chip

Digital Signal Processor

SAA7715AH

SYMBOL	PIN	PIN TYPE	DESCRIPTION
DIV_CLK_IN	41	ipthdt5v	divide the input frequency on pin CLK_IN by two
DSP_INOUT5	42	bpts5thdt5v	digital input/output flag of the DSP-core (F5 of the status register)
DSP_INOUT6	43	bpts5thdt5v	digital input/output flag of the DSP-core (F6 of the status register)
DSP_INOUT7	44	bpts5thdt5v	digital input/output flag of the DSP-core (F7 of the status register)

Table 1 Brief explanation of used pin types

PIN TYPE	EXPLANATION
apio	analog I/O pad cell; actually pin type vddco
bpts5thdt5v	43 MHz bidirectional pad; push-pull input; 3-state output; 5 ns slew rate control; TTL; hysteresis; pull-down; 5 V tolerant
bpts5tht5v	43 MHz bidirectional pad; push-pull input; 3-state output; 5 ns slew rate control; TTL; hysteresis; 5 V tolerant
bpt4mthdt5v	bidirectional pad; push-pull input; 3-state output; 4 mA output drive; TTL; hysteresis; pull-down; 5 V tolerant
iic400kt5v	I ² C-bus pad; 400 kHz I ² C-bus specification; 5 V tolerant
ipthdt5v	input pad buffer; TTL; hysteresis; pull-down; 5 V tolerant
iptht5v	input pad buffer; TTL; hysteresis; 5 V tolerant
ipthut5v	input pad buffer; TTL; hysteresis; pull-up; 5 V tolerant
ops5c	output pad; push-pull; 5 ns slew rate control; CMOS
op4mc	output pad; push-pull; 4 mA output drive
vddco	V _{DD} supply to core only
vdde	V _{DD} supply to peripheral only
vddi	V _{DD} supply to core only
vddo	V _{DD} supply to core only
vssco	V _{SS} supply to core only (vssco does not connect the substrate)
vsse	V _{SS} supply to peripheral only
vssi	V _{SS} supply to core and peripheral
vssis	V _{SS} supply to core only; with substrate connection
vssso	V _{SS} supply to core only

Digital Signal Processor

SAA7715AH

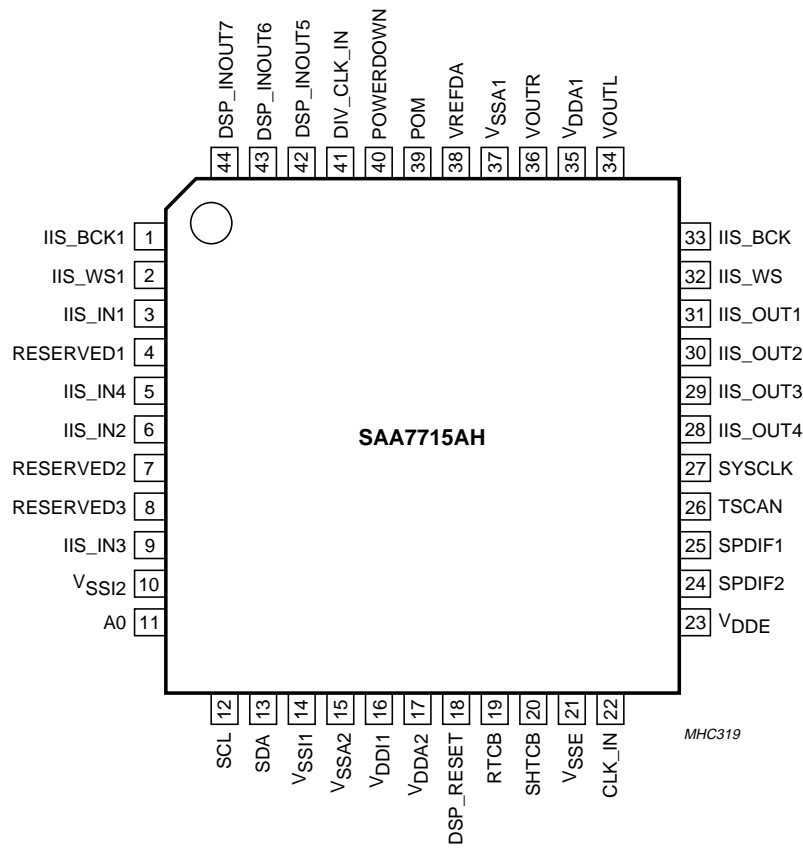

Fig.2 Pin configuration.

Digital Signal Processor

SAA7715AH

8 FUNCTIONAL DESCRIPTION

8.1 PLL clock division factors for different clock inputs

An on-chip PLL generates the clock for the DSP. The DSP runs at a selectable frequency of maximum 70 MHz. The clock is generated with the PLL that uses the CLK_IN of the chip to generate the DSP clock. Table 2 gives the PLL clock division factor and the values of the dsp_turbo and the DIV_CLK_IN bits that need to be set via the I²C-bus (see Table 10).

Table 2 PLL clock division factor per clock input.

CLK_IN (MHz)	pll_div[4:0]	N	dsp_turbo	DIV_CLK_IN	DSP CLOCK (MHz)
8.192 (32 kHz × 256)	10H	272	1	0	69.632
9.728 (38 kHz × 256)	09H	227	1	0	69.008
11.2896 (44.1 kHz × 256)	03H	198	1	0	69.854
12.288 (48 kHz × 256)	00H	181	1	0	69.504
16.384 (32 kHz × 512)	10H	272	1	1	69.632
18.432 (32 kHz × 576)	0BH	244	1	1	68.544
19.456 (38 kHz × 512)	09H	227	1	1	69.008
24.576 (96 kHz × 256)	00H	181	1	1	69.504

The above table does NOT imply that the clock input is restricted to the values given in this table. The clock input is restricted to be within the range of 8.192 to 12.228 MHz. For higher clock frequencies pin DIV_CLK_IN should be set to logic 1 performing a divide-by-2 of the CLK_IN signal and thereby doubling the CLK_IN frequency range that is allowed (16.384 to 24.576 MHz).

8.2 The word select PLL

A second on-chip PLL generates a selectable multiple of the sample rate frequency supplied on the word select pin IIS_WS (= IIS_WS1). The clock generated by this so called WS_PLL is available for the user at pin SYSCLK. Tables 3 and 4 show the I²C-bus settings needed to generate the $n \times f_s$ clock. The memory map of the I²C-bus bits is shown in Table 10.

Table 3 Word select input range selection

SAMPLE RATE OF f_s (kHz)	sel_loop_div[1:0]
32 to 50	01
50 to 96	00

Table 4 Selection of $n \times f_s$ clock at SYSCLK output

sel2	sel1	sel0	SYSCLK ($n \times$ IIS_WS1)	DUTY FACTOR
1	0	0	512	50% for 32 to 50 kHz input; 66% for 50 to 96 kHz input
0	1	1	384	50%
0	1	0	256	50%
0	0	1	192	50%
0	0	0	128	50%

Digital Signal Processor

SAA7715AH

8.3 The Filter Stream DAC (FSDAC)

The FSDAC is a semi-digital reconstruction filter that converts the 1-bit data stream of the noise shaper to an analog output voltage. The filter coefficients are implemented as current sources and are summed at virtual ground of the output operational amplifier. In this way very high signal-to-noise performance and low clock jitter sensitivity is achieved. A post-filter is not needed due to the inherent filter function of the DAC. On-board amplifiers convert the FSDAC output current to an output voltage signal capable of driving a line output.

The output voltage of the FSDAC scales proportionally with the power supply voltage.

8.3.1 INTERPOLATION FILTER

The digital filter interpolates from 1 to $64f_s$ by means of a cascade of a recursive filter and an FIR filter.

Table 5 Digital interpolation filter characteristics

ITEM	CONDITIONS	VALUE (dB)
Pass band ripple	0 to $0.45f_s$	± 0.03
Stop band	$>0.55f_s$	-50
Dynamic range	0 to $0.45f_s$	116.5
Gain	DC	-3.5

8.3.2 NOISE SHAPER

The 5th-order noise shaper operates at $64f_s$. It shifts in-band quantization noise to frequencies well above the audio band. This noise shaping technique enables high signal-to-noise ratios to be achieved. The noise shaper output is converted into an analog signal using a filter stream digital-to-analog converter.

8.3.3 FUNCTION OF PIN POM

With pin POM it is possible to switch off the reference current of the DAC. The capacitor on pin POM determines the time after which this current has a soft switch-on. So at power-on the current audio signal outputs are always muted. The loading of the external capacitor is done in two stages via two different current sources. The loading starts at a current level that is lower than the current loading after the voltage on pin POM has passed a particular level. This results in an almost dB-linear behaviour. This prevents 'plop' effects during power on/off.

8.3.4 POWER OFF PLOP SUPPRESSION

To avoid plops in a power amplifier, the supply voltage of the analog part of the DAC and the rest of the chip can be fed from a separate supply of 3.3 V. A capacitor connected to this supply enables to provide power to the analog part at the moment the digital voltage is switching off fast. In this event the output voltage will decrease gradually allowing the power amplifier some extra time to switch off without audible plops.

8.3.5 PIN VREFDA FOR INTERNAL REFERENCE

With two internal resistors half the supply voltage V_{DDA1} is obtained and used as an internal reference. This reference voltage is used as DC voltage for the output operational amplifiers and as reference for the DAC. In order to obtain the lowest noise and to have the best ripple rejection, a filter capacitor has to be added between this pin and ground, preferably close to the analog pin V_{SSA1} .

8.3.6 SUPPLY OF THE ANALOG OUTPUTS

The entire analog circuitry of the DACs and the OPAMPS are supplied by 2 supply pins, V_{DDA1} and V_{SSA1} . The V_{DDA1} must have sufficient decoupling to prevent THD degradation and to ensure a good Power Supply Rejection Ratio (PSRR). The digital part of the DAC is fully supplied from the chip core supply.

8.4 External control pins

The flags DSP_INOUT5 to DSP_INOUT7 are available as external pins. The flags can be used by the DSP depending on the downloaded software.

Digital Signal Processor

SAA7715AH

8.5 Digital serial inputs/outputs and SPDIF inputs

8.5.1 DIGITAL SERIAL INPUTS/OUTPUTS

For communication with external digital sources a digital serial bus is implemented. It is a serial 3-line bus, having one line for data, one line for clock and one line for the word select. For external digital sources the SAA7715AH acts as a slave, so the external source is master and supplies the clock.

For the I²S-bus format itself see the official specification from Philips.

The digital serial input is capable of handling Philips I²S-bus and LSB-justified formats of 16, 18, 20 and 24 bits word sizes. The sampling frequency can be 32 up to 96 kHz. See "9.8 I²C-bus memory map definition" for the bits that must be programmed, for selection of the desired serial format.

See Fig.3 for the general waveforms of the possible formats.

When the applied word length exceeds 24 bits, the LSBs are skipped.

The digital serial input/output circuitry is limited in handling the number of BCK pulses per WS period. The maximum allowed number of bit clocks per WS period is 256. Also the number of bit clocks during WS LOW and HIGH must be equal (50% WS duty factor) only for the LSB-justified formats.

There are two modes in which the digital inputs can be used (the mode is selectable via an I²C-bus bit):

- Use up to 4 digital serial inputs (8ch) with common WS and BCK signal (8ch IN and 8ch OUT + 2ch FSDAC output)
- Use one of the 2 SPDIF inputs as source instead of the use of the digital serial inputs (2ch IN and 8ch OUT + One 2ch FSDAC output).

8.5.2 SPDIF INPUTS

Two separate SPDIF receivers are available, one shared with digital serial input 2 (SPDIF1) and one with the digital serial input 3 (SPDIF2). The sample frequency at which the SPDIF inputs can be used must be in the range of 32 to 96 kHz.

There are few control signals available from the SPDIF input stage. These are connected to flags of the DSP:

- A lock signal indicating if the SPDIF input 1 or 2 is in lock
- The pcm_audio/non-pcm_audio bit indicating if an audio or data stream is detected on SPDIF input 1 or 2. The FSDAC output will NOT be muted in the event of non-audio PCM stream. This status bit can be read via the I²C-bus, the microprocessor controller can decide to put the DAC into MUTE (via pin POM).

Handling of channel status bits: The first 40 (of 192) channel status bits of the selected SPDIF source (0FFBH, bit 20), will come available in the I²C-bus registers 0FF2H to 0FF5H. Two registers 0FF2H to 0FF3H contain the information for the right channel, the other two (0FF4H to 0FF5H) contain the information for the left channel. The information can be read via I²C-bus or by the DSP program.

The design fulfils the digital audio interface specification "IEC 60958-1 Ed2, part 1, general part IEC 60958-3 Ed2, part 3, consumer applications".

Digital Signal Processor

SAA7715AH

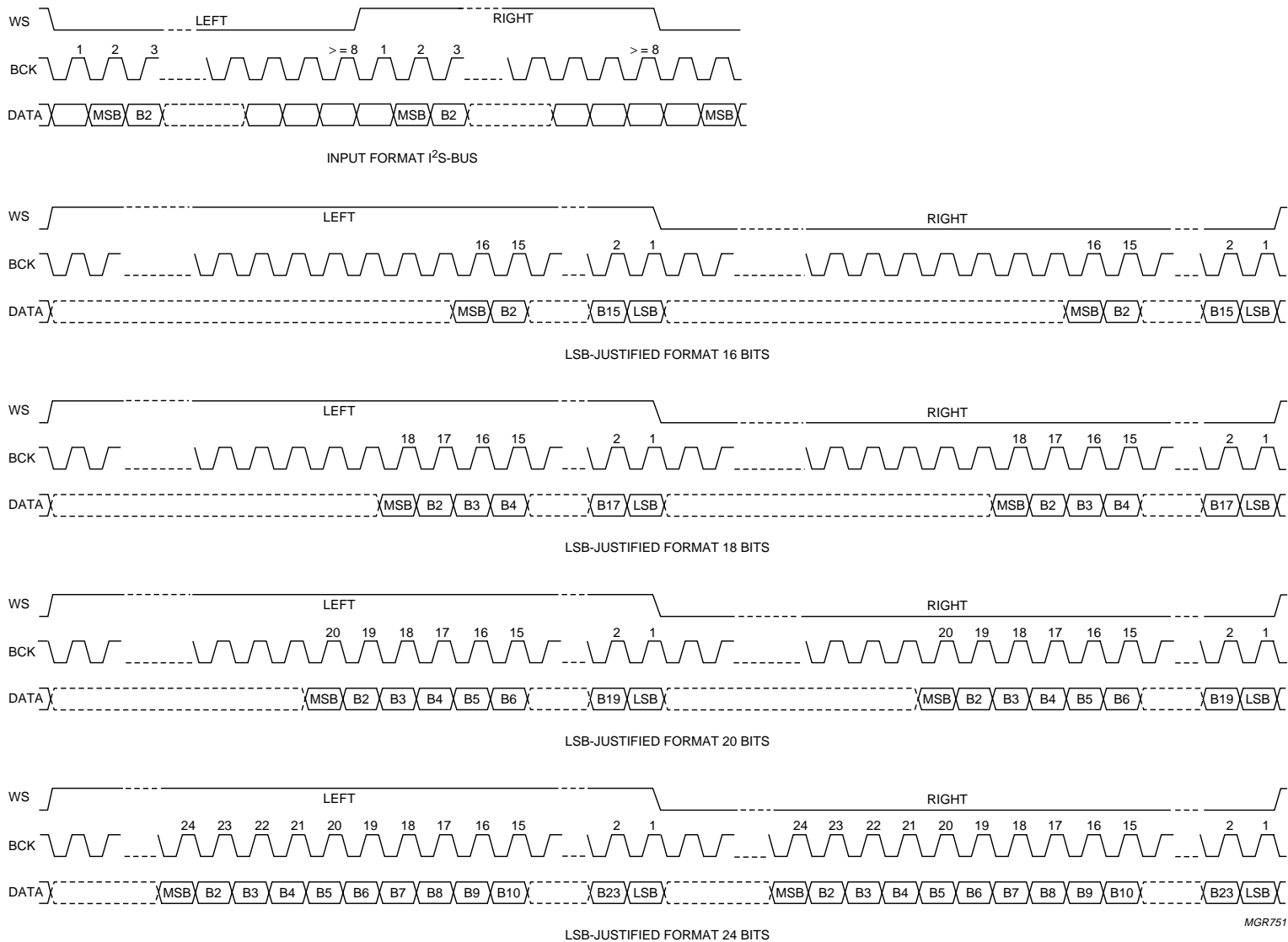

Fig.3 All serial data input/output formats.

Digital Signal Processor

SAA7715AH

8.6 I²C-bus interface (pins SCL and SDA)

The I²C-bus format is described in "The I²C-bus and how to use it", order no. 9398 393 40011.

For the external control of the SAA7715AH a fast I²C-bus is implemented. This is a 400 kHz bus which is downward compatible with the standard 100 kHz bus.

There are two different types of control instructions:

- Loading of the Program RAM (PRAM) with the required DSP program
 - Programming the coefficient RAM (YRAM)
 - Instructions to control the DSP program.
- Selection of the digital serial input/output format to be used, the DSP clock speed.

The detailed description of the I²C-bus and the description of the different bits in the memory map is given in Chapter 9.

8.7 Reset

The reset (pin DSP_RESET) is active LOW and needs an external 22 kΩ pull-up resistor. Between this pin and the V_{SS1} ground a capacitor of 1 μF should be connected to allow a proper switch-on of the supply voltage. The capacitor value is such that the chip is in reset as long as the power supply is not stabilized. A more or less fixed relationship between the DSP reset and the POM time constant is obligatory. The voltage on pin POM determines the current flowing in the DACs.

The reset sets all I²C-bus bits to their default value and it restarts the DSP program.

8.8 Power-down mode

The Power-down mode switches off all activity on the chip. The Power-down mode can be switched on and off using pin POWERDOWN. This pin needs to be connected to ground if not used. The following applies for the Power-down mode:

- Power-down mode may only be switched on when there is no I²C-bus activity to or from the SAA7715AH
- Power-down mode may not be switched on before the complete chip has been reset (DSP_RESET active LOW)
- The clock signal on pin CLK_IN should be running during Power-down mode
- It is advised to set pin POM to logic 0 before switching on the Power-down mode and set it back to logic 1 after the chip actually returns from Power-down mode as shown in Fig.4
- All on-chip registers and memories will keep their values during Power-down mode
- Digital serial outputs are not muted, the last value is kept on the output
- The SAA7715AH will not 'lock-up' the I²C-bus during Power-down mode (SDA line).

Figure 4 shows the time the chip actually is in Power-down mode after switching on/off pin POWERDOWN.

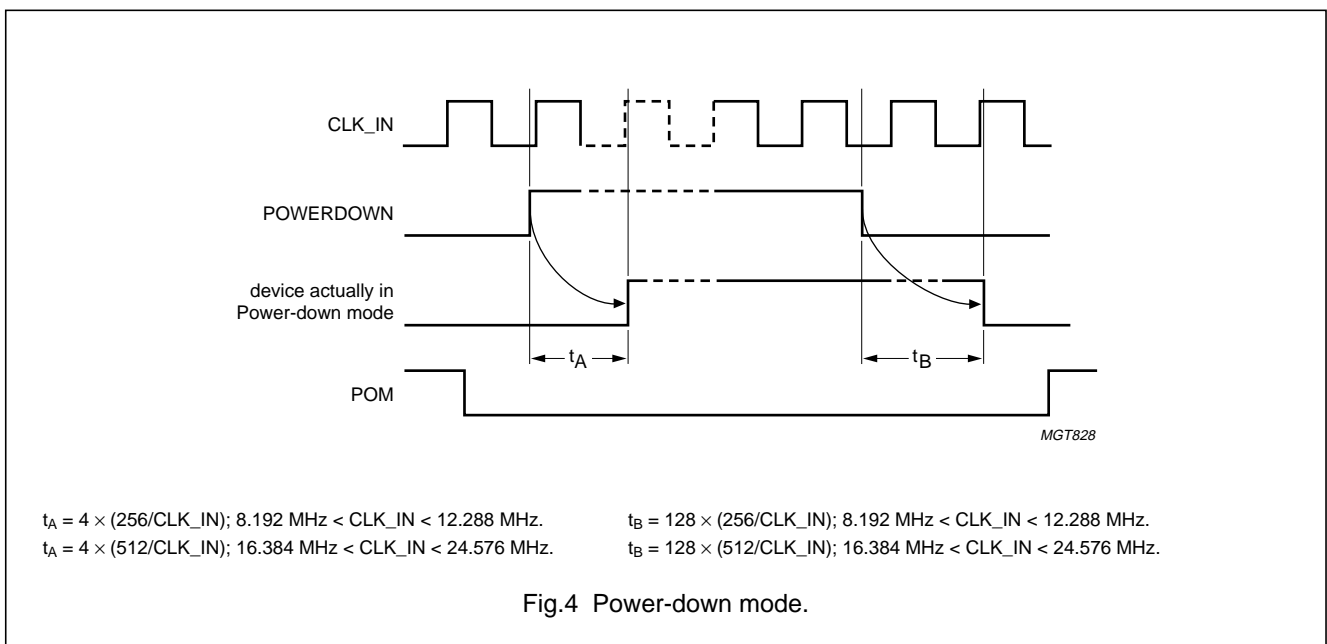

Digital Signal Processor

SAA7715AH

8.9 Power supply connection and EMC

The digital part of the chip has in total 4 positive supply line connections and 5 ground connections. To minimize radiation the chip should be put on a double layer printed-circuit board with on one side a large ground plane. The ground supply lines should have a short connection to this ground plane. A coil/capacitor network in the positive supply line of the peripheral power supply line can be used as high frequency filter. The core supply lines (V_{DD1}) have an on-chip decoupling capacitance, for EMC reasons an external decoupling capacitance must not be used on this pin. A series resistor plus capacitance is required for proper operation on pin V_{DDA2} , see Fig.9.

8.10 Test mode connections (pins TSCAN, RTCB and SHTCB)

Pins TSCAN, RTCB and SHTCB are used to put the chip in test mode and to test the internal connections. Each pin has an internal pull-down resistor to ground. In the application these pins can be left open or connected to ground.

9 I²C-BUS PROTOCOL**9.1 Addressing**

Before any data is transmitted on the I²C-bus, the device that should respond is addressed first. The addressing is always done with the first byte transmitted after the start procedure.

9.2 Slave address (pin A0)

The SAA7715AH acts as a slave receiver or a slave transmitter. Therefore the clock signal SCL is only an input signal. The data signal SDA is a bidirectional line. The slave address is shown in Table 6.

Table 6 Slave address

MSB							LSB
0	0	1	1	1	1	A0	R/W

The sub-address bit A0 corresponds to the hardware address pin A0 which allows the device to have 2 different addresses. The A0 input is also used in test mode as serial input of the test control block.

9.3 Write cycles

The I²C-bus configuration for a write cycle is shown in Fig.5. The write cycle is used to write the bytes to the DSP for manipulating the data and coefficients. More details can be found in the I²C-bus memory map, see Table 8.

The data length is 2, 3 or 4 bytes depending on the accessed memory. If the Y-memory is addressed the data length is 2 bytes, in the event of the X-memory the length is 3 bytes. The slave receiver detects the address and adjusts the number of bytes accordingly.

For this RAM-based product the internal P-memory (PRAM) can be accessed via the I²C-bus interface. The transmitted data stream should be 4 bytes.

9.4 Read cycles

The I²C-bus configuration for a read cycle is shown in Fig.6. The read cycle is used to read the data values from XRAM, YRAM or PRAM. The master starts with a START condition S, the SAA7715AH address '0011110' and a logic 0 (write) for the read/write bit. This is followed by an acknowledge of the SAA7715AH. Then the master writes the high memory address (ADDR H) and low memory address (ADDR L) where the reading of the memory content of the SAA7715AH must start. The SAA7715AH acknowledges these addresses both.

The master generates a repeated START (Sr) and again the SAA7715AH address '0011110' but this time followed by a logic 1 (read) of the read/write bit. From this moment on the SAA7715AH will send the memory content in groups of 3 (X/Y-memory or registers) or 4 (P-memory) bytes to the I²C-bus each time acknowledged by the master. The master stops this cycle by generating a negative acknowledge, then the SAA7715AH frees the I²C-bus and the master can generate a STOP condition.

The data is transferred from the DSP register to the I²C-bus register at execution of the MPI instruction in the DSP program. Therefore at least once every DSP routine an MPI instruction should be added.

Digital Signal Processor

SAA7715AH

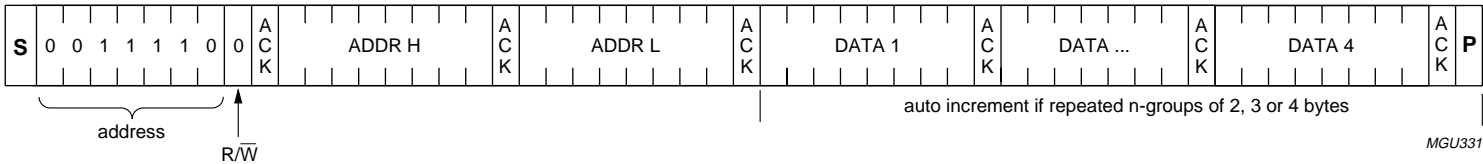

S = START condition.
 P = STOP condition.
 ACK = acknowledge from SAA7715AH.
 ADDR H and ADDR L = address DSP register.
 DATA 1 to DATA 4 = 2, 3 or 4 bytes data word.

Fig.5 Master transmitter writes to the SAA7715AH registers.

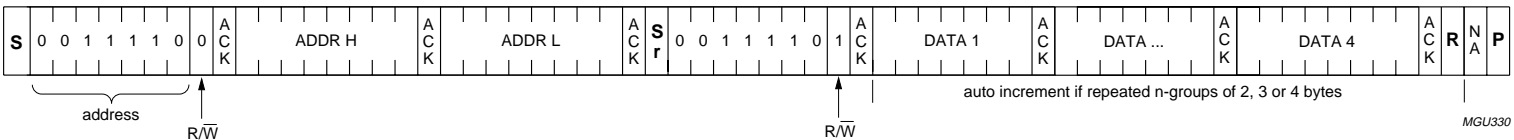

S = START condition.
 Sr = repeated START condition.
 P = STOP condition.
 ACK = acknowledge from SAA7715AH (SDA LOW).
 R = repeat n-times the 2, 3 or 4 bytes data group.
 NA = Negative Acknowledge master (SDA HIGH).
 ADDR H and ADDR L = address DSP register.
 DATA 1 to DATA 4 = 2, 3 or 4 bytes data word.

Fig.6 Master transmitter reads from the SAA7715AH registers.

Digital Signal Processor

SAA7715AH

9.5 Program RAM

The SAA7715AH has a 1.5 kbyte PRAM to store the DSP instruction code into. Also a 2 kbyte PROM is on-chip available and can be accessed (memory mapped) without the need of selecting the PROM or PRAM. The DSP instruction code can be downloaded into the PRAM via the I²C-bus. The write and read cycle are shown in Figs 5 and 6 respectively.

The DSP has an instruction word width of 32 bits which means that this space should be accessed with 4 bytes in consecutive order and does have the auto-increment function.

9.6 Data word alignment

It is possible to transfer data via the I²C-bus to a destination where it can have different data word length. Those destinations with data word are shown in Table 7.

Table 7 Data word alignment

SOURCE	DESTINATION	DATA WORD	BYTES (NUMBER)
I ² C-bus	DSP-PRAM	MBBB BBBB BBBB BBBB BBBB BBBB BBBB BBBL	4
I ² C-bus	DSP and general control	MBBB BBBB BBBB BBBB BBBB BBBL	3
I ² C-bus	I ² C-bus registers	MBBB BBBB BBBB BBBB BBBB BBBL	3
I ² C-bus	DSP-XRAM	MBBB BBBB BBBB BBBB BBBB BBBL	3
I ² C-bus	DSP-YRAM	XXXX MBBB BBBB BBBL	2

Digital Signal Processor

SAA7715AH

9.7 I²C-bus memory map specification

The I²C-bus memory map contains all defined I²C-bus bits. The map is split up in two different sections: the hardware memory registers and the RAM definitions. In Table 8 the preliminary memory map is depicted. The hardware registers are memory map on the XRAM of DSP. Table 9 shows the detailed memory map of those locations. All locations are acknowledged by the SAA7715AH even if the user tries to write to a reserved space. The data in these sections will be lost. Reading from these locations will result in undefined data words.

Table 8 I²C-bus memory map

ADDRESS	FUNCTION	SIZE
8000H to 87FFH	DSP to PROM (not readable via I ² C-bus)	2k × 32 bits
602FH	DSP and general control	1 × 24 bits
2000H to 25FFH	DSP to PRAM	1.5k × 32 bits
1000H to 15FFH	DSP to YRAM	1.5k × 12 bits
0FF2H to 0FF5H, 0FFBH	I ² C-bus register	5 × 24 bits
0000H to 0B7FH	DSP to XRAM	2.875k × 24 bits

Table 9 I²C-bus memory map overview

ADDRESS	DESCRIPTION
Hardware registers	
0FFBH	Selector register 1
0FF5H	SPDIF IN channel status register 1 left
0FF4H	SPDIF IN channel status register 2 left
0FF3H	SPDIF IN channel status register 1 right
0FF2H	SPDIF IN channel status register 2 right
DSP control	
602FH	DSP and general control register

Digital Signal Processor

SAA7715AH

9.8 I²C-bus memory map definition

Table 10 DSP and general control register (602FH)

NAME	SIZE (BITS)	DESCRIPTION	DEFAULT	BIT POSITION
	1	reserved	0	0
pll_div[4:0]	5	PLL clock division factor according to Table 2	00011	5 to 1
dsp_turbo	1	PLL output frequency 1: double 0: no doubling	1	6
	1	reserved	1	7
pc_reset_dsp	1	program counter reset DSP 1: reset on 0: reset off	0	8
	2	reserved	00	10 to 9
sel[2:0]	3	selection of $n \times f_s$ clock at SYSCLK output according to Table 4	010	13 to 11
sel_loop_div[1:0]	2	word select input range selection for WS_PLL according to Table 3	01	15 to 14
	2	reserved	00	17 to 16
sel_FSDAC_clk	2	clock source for FSDAC 00: WS_PLL if no signal to pin CLK_IN 01: $512f_s$ to pin CLK_IN 11: $256f_s$ to pin CLK_IN	00	19 to 18
dis_SYSCLK	1	output on pin SYSCLK 1: disable 0: enable	0	20
256f _s *n*Fs	1	signal on pin SYSCLK 1: fixed $256f_s$ clock 0: $n \times f_s$ clock; determined by bits 13 to 11	0	21
	2	reserved	00	23 to 22

Table 11 SPDIF IN channel status register 2 right (0FF2H)

NAME	SIZE (BITS)	DESCRIPTION	DEFAULT	BIT POSITION
ch_stat_in right lsb	20	channel status SPDIF in right LSB bits 19 to 0	00000H	19 to 0

Table 12 SPDIF IN channel status register 1 right (0FF3H)

NAME	SIZE (BITS)	DESCRIPTION	DEFAULT	BIT POSITION
ch_stat_in right msb	20	channel status SPDIF in right MSB bits 39 to 20	00000H	19 to 0

Digital Signal Processor

SAA7715AH

Table 13 SPDIF IN channel status register 2 left (0FF4H)

NAME	SIZE (BITS)	DESCRIPTION	DEFAULT	BIT POSITION
ch_stat_in left lsb	20	channel status SPDIF in2 left LSB bits 19 to 0	00000H	19 to 0

Table 14 SPDIF IN channel status register 1 left (0FF5H)

NAME	SIZE (BITS)	DESCRIPTION	DEFAULT	BIT POSITION
ch_stat_in left msb	20	channel status SPDIF in2 left MSB bits 39 to 20	00000H	19 to 0

Table 15 Selector register 1 (0FFBH)

NAME	SIZE (BITS)	DESCRIPTION	DEFAULT	BIT POSITION
format_in1	3	digital serial inputs 1 and 4 data format according to Table 17	011	2 to 0
format_in2	3	digital serial input 2 data format according to Table 17	011	5 to 3
format_in3	3	digital serial input 3 data format according to Table 17	011	8 to 6
format_out	3	digital serial outputs 1 to 4 data format according to Table 18	000	11 to 9
en_output	1	enable or disable digital serial outputs 1: enable 0: disable	1	12
	1	reserved	0	13
master_source	4	source selection 0000: digital serial input 1 0101: digital serial input 2 or SPDIF 1 (see bit 18) 1010: digital serial input 3 or SPDIF 2 (see bit 19) all other values are reserved	0000	17 to 14
spdif_sel1	1	SPDIF1 or digital serial input 2 1: SPDIF1 0: digital serial input 2	0	18
spdif_sel2	1	SPDIF2 or digital serial input 3 1: SPDIF2 0: digital serial input 3	0	19
sel_spdifin_chstat	1	select channel status information taken from SPDIF1 or SPDIF2 1: from input SPDIF2 0: from input SPDIF1	0	20
	3	reserved	000	23 to 21

Digital Signal Processor

SAA7715AH

Table 16 Default settings of I²C-bus registers after power-up and reset

I ² C-BUS ADDRESS	DEFAULT VALUE
602FH	0050C6H
0FFBH	0010DBH
0FF5H	000000H
0FF4H	000000H
0FF3H	000000H
0FF2H	000000H

9.9 Table definitions

Table 17 Digital serial format for inputs 1 to 4

format_in1, 2 and 3			INPUT
BIT 2	BIT 1	BIT 0	
0	1	1	standard I ² S-bus
1	0	0	LSB-justified, 16 bits
1	0	1	LSB-justified, 18 bits
1	1	0	LSB-justified, 20 bits
1	1	1	LSB-justified, 24 bits

Table 18 Digital serial formats for outputs 1 to 4

format_out			OUTPUT
BIT 2	BIT 1	BIT 0	
0	0	0	standard I ² S-bus
1	0	0	LSB-justified, 16 bits
1	0	1	LSB-justified, 18 bits
1	1	0	LSB-justified, 20 bits
1	1	1	LSB-justified, 24 bits

10 SOFTWARE IN ROM DESCRIPTION

The function of this chip is related to the PROM code (ROM code dependent).

Digital Signal Processor

SAA7715AH

11 LIMITING VALUES

In accordance with the Absolute Maximum Ratings System (IEC 60134).

SYMBOL	PARAMETER	CONDITIONS	MIN.	MAX.	UNIT
V_{DD}	supply voltage		-0.5	+3.6	V
V_I	input voltage		-0.5	+5.5	V
I_{IK}	input clamping diode current	$V_I < -0.5 \text{ V}$ or $V_I > V_{DD} + 0.5 \text{ V}$	-	± 10	mA
I_{OK}	output clamping diode current	$V_O < -0.5 \text{ V}$ or $V_O > V_{DD} + 0.5 \text{ V}$	-	± 20	mA
$I_{O(\text{sink/source})}$	output source or sink current	$-0.5 \text{ V} < V_O < V_{DD} + 0.5 \text{ V}$	-	± 20	mA
I_{DD}, I_{SS}	V_{DD} or V_{SS} current per supply pin		-	± 50	mA
T_{amb}	ambient temperature		-40	+85	°C
T_{stg}	storage temperature		-65	+125	°C
V_{ESD}	electrostatic handling voltage	note 1	200	-	V
		note 2	2000	-	V
$I_{lu(\text{prot})}$	latch-up protection current	CIC specification/test method	100	-	mA
P_{tot}	total power dissipation		-	600	mW

Notes

- Machine model ($R = 0 \text{ } \Omega$; $C = 100 \text{ pF}$; $L = 2.5 \text{ } \mu\text{H}$).
- Human body model ($R = 1500 \text{ } \Omega$; $C = 100 \text{ pF}$).

12 THERMAL CHARACTERISTICS

SYMBOL	PARAMETER	CONDITIONS	VALUE	UNIT
$R_{th(j-a)}$	thermal resistance from junction to ambient	mounted on printed-circuit board	60	K/W

Digital Signal Processor

SAA7715AH

13 CHARACTERISTICS $V_{DD} = 3.15$ to 3.45 V; unless otherwise specified.

SYMBOL	PARAMETER	CONDITIONS	MIN.	TYP.	MAX.	UNIT
Supplies; $T_{amb} = -40$ to $+85$ °C						
V_{DD}	operating supply voltage	all pins V_{DD} with respect to pins V_{SS}	3.15	3.3	3.45	V
I_{DD}	supply current of the digital part		–	95	–	mA
$I_{DD}(\text{core})$	supply current of the digital core part	high activity of the DSP at DSPFREQ frequency	–	90	–	mA
$I_{DD}(\text{peri})$	supply current of the digital periphery part	no external load to ground	–	5	–	mA
I_{DDA}	supply current of the analog part	zero input and output signal	–	20	–	mA
$I_{DDA}(\text{DAC})$	supply current of the DAC	zero input and output signal	–	6.5	13	mA
		Power-down mode	–	250	–	μA
$I_{DDA}(\text{SPDIF})$	supply current of the SPDIF inputs, on-chip PLL and WSPLL	zero input and output signals	–	13.5	27	mA
P_{tot}	total power dissipation		–	380	–	mW
$I_{\text{POWERDOWN}}$	DC supply current of the total chip in Power-down mode	pin POWERDOWN enabled	–	400	–	μA
Digital I/O; $T_{amb} = -40$ to $+85$ °C; $V_{DD} = 3.15$ to 3.45 V; unless otherwise specified						
V_{IH}	HIGH-level input voltage all digital inputs and I/Os		2.0	–	–	V
V_{IL}	LOW-level input voltage all digital inputs and I/Os		–	–	0.8	V
V_{hys}	Schmitt-trigger hysteresis		0.4	–	–	V
V_{OH}	HIGH-level output voltage	standard output; $I_O = -4$ mA	$V_{DD} - 0.4$	–	–	V
		5 ns slew rate output; $I_O = -4$ mA	$V_{DD} - 0.4$	–	–	V
		10 ns slew rate output; $I_O = -2$ mA	$V_{DD} - 0.4$	–	–	V
		20 ns slew rate output; $I_O = -1$ mA	$V_{DD} - 0.4$	–	–	V

Digital Signal Processor

SAA7715AH

SYMBOL	PARAMETER	CONDITIONS	MIN.	TYP.	MAX.	UNIT
V _{OL}	LOW-level output voltage	standard output; I _O = 4 mA	–	–	0.4	V
		5 ns slew rate output; I _O = 4 mA	–	–	0.4	V
		10 ns slew rate output; I _O = 2 mA	–	–	0.4	V
		20 ns slew rate output; I _O = 1 mA	–	–	0.4	V
		I ² C-bus output; I _O = 4 mA	–	–	0.4	V
I _{LO}	output leakage current 3-state outputs	V _O = 0 V or V _{DD}	–	–	±5	μA
R _{pd}	internal pull-down resistor to V _{SS}		24	50	140	kΩ
R _{pu}	internal pull-up resistor to V _{DD}		30	50	100	kΩ
C _i	input capacitance		–	–	3.5	pF
t _{i(r)} , t _{i(f)}	input rise and fall times	V _{DD} = 3.45 V	–	6	200	ns
t _{o(t)}	output transition time	standard output; C _L = 30 pF	–	3.5	–	ns
		5 ns slew rate output; C _L = 30 pF	–	5	–	ns
		10 ns slew rate output; C _L = 30 pF	–	10	–	ns
		20 ns slew rate output; C _L = 30 pF	–	20	–	ns
		I ² C-bus output; C _L = 400 pF	60	–	300	ns
AC characteristics SPDIF1 and SPDIF2 inputs; T_{amb} = 25 °C; V_{DDA2} = 3.3 V; unless otherwise specified						
V _{i(p-p)}	AC input level (peak-to-peak level)		0.2	0.5	3.3	V
R _i	input impedance	at 1 kHz	–	6	–	kΩ
V _{hys}	hysteresis of input voltage		–	40	–	mV
Analog DAC outputs; V_{DDA1} = 3.3 V; f_s = 44.1 kHz; T_{amb} = 25 °C; R_L = 5 kΩ; all voltages referenced to ground; unless otherwise specified						
DC CHARACTERISTICS						
R _{o(DAC)}	DAC output resistance		–	0.13	3.0	Ω
I _{o(max)}	maximum output current	(THD + N)/S < 0.1% R _L = 5 kΩ	–	0.22	–	mA
R _L	load resistance		3	–	–	kΩ
C _L	load capacitance		–	–	200	pF
R _{o(VREFDA)}	VREFDA output resistance		–	28	–	kΩ
AC CHARACTERISTICS						
V _{o(rms)}	output voltage (RMS value)		–	1000	–	mV
ΔV _o	unbalance between channels		–	0.1	–	dB

Digital Signal Processor

SAA7715AH

SYMBOL	PARAMETER	CONDITIONS	MIN.	TYP.	MAX.	UNIT
(THD + N)/S	total harmonic distortion plus noise-to-signal ratio	at 0 dB	–	–85	–	dB(A)
		at –60 dB	–	–37	–	dB(A)
S/N	signal-to-noise ratio	code = 0	–	100	–	dB(A)
α_{CS}	channel separation		–	80	–	dB
PSRR	power supply rejection ratio	$f_{\text{ripple}} = 1 \text{ kHz};$ $V_{\text{ripple(p-p)}} = 1\%$	–	50	–	dB

Digital Signal Processor

SAA7715AH

14 I²S-BUS TIMING

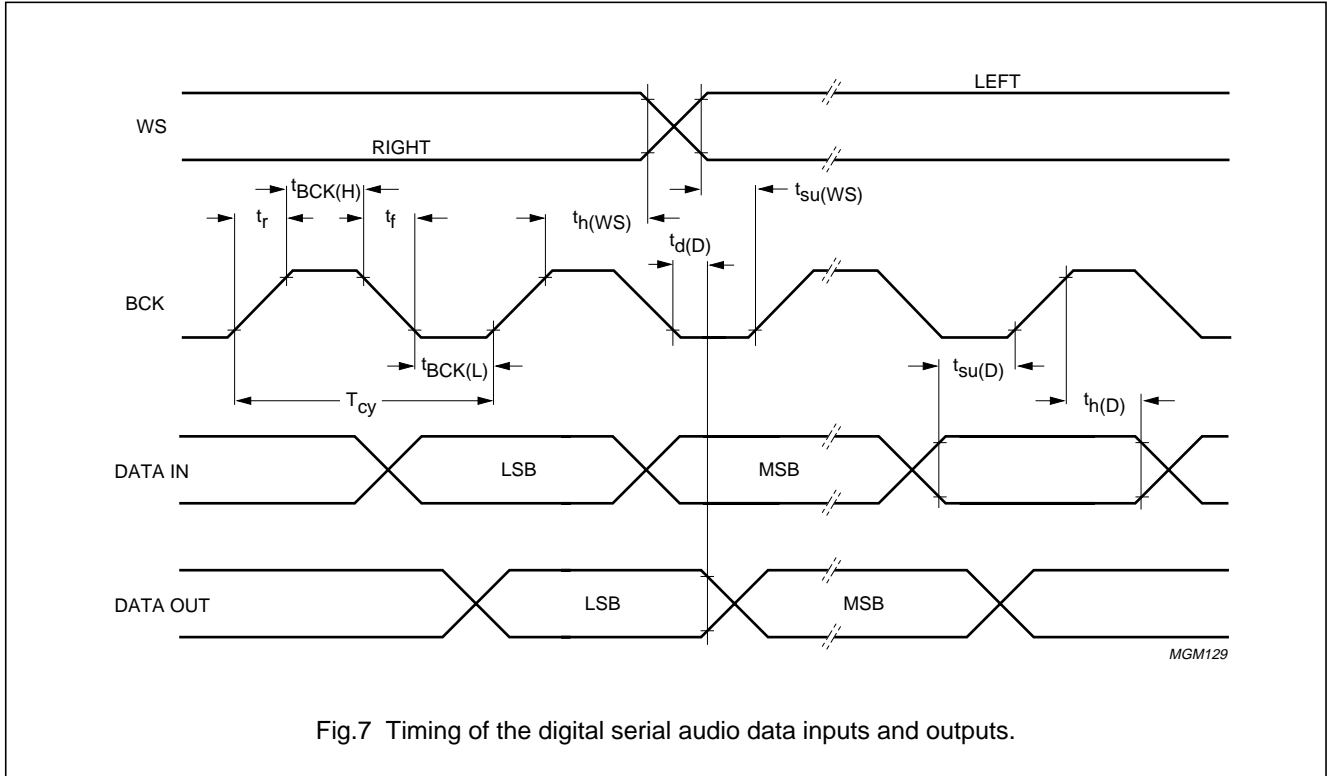

Fig.7 Timing of the digital serial audio data inputs and outputs.

Table 19 Timing of the digital serial audio data inputs and outputs (see Fig.7)

SYMBOL	PARAMETER	CONDITIONS	MIN.	TYP.	MAX.	UNIT
T_{cy}	bit clock cycle time		162	–	–	ns
t_r	rise time	$T_{cy} = 50 \text{ ns}$	–	–	$0.15T_{cy}$	ns
t_f	fall time	$T_{cy} = 50 \text{ ns}$	–	–	$0.15T_{cy}$	ns
$t_{BCK(H)}$	bit clock HIGH time	$T_{cy} = 50 \text{ ns}$	$0.35T_{cy}$	–	–	ns
$t_{BCK(L)}$	bit clock LOW time	$T_{cy} = 50 \text{ ns}$	$0.35T_{cy}$	–	–	ns
$t_{su(D)}$	data set-up time	$T_{cy} = 50 \text{ ns}$	$0.2T_{cy}$	–	–	ns
$t_h(D)$	data hold time	$T_{cy} = 50 \text{ ns}$	$0.2T_{cy}$	–	–	ns
$t_d(D)$	data delay time	$T_{cy} = 50 \text{ ns}$	–	–	$0.15T_{cy}$	ns
$t_{su(WS)}$	word select set-up time	$T_{cy} = 50 \text{ ns}$	$0.2T_{cy}$	–	–	ns
$t_h(WS)$	word select hold time	$T_{cy} = 50 \text{ ns}$	$0.2T_{cy}$	–	–	ns

Digital Signal Processor

SAA7715AH

15 I²C-BUS TIMING

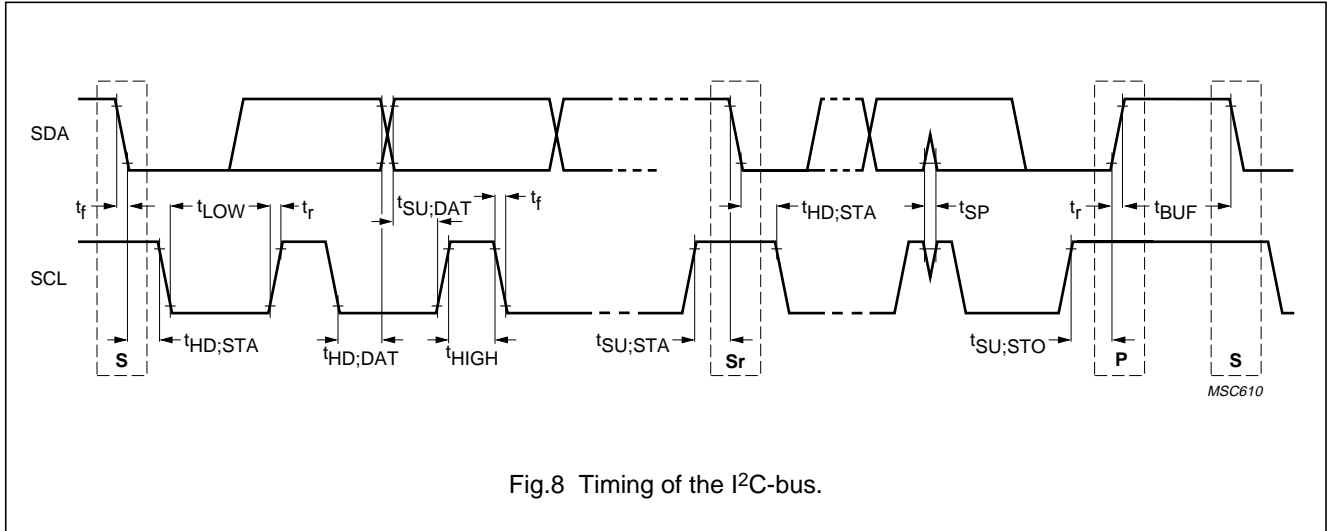

Fig.8 Timing of the I²C-bus.

Table 20 Timing of the I²C-bus (see Fig.8)

SYMBOL	PARAMETER	CONDITIONS	STANDARD MODE I ² C-BUS		FAST MODE I ² C-BUS		UNIT
			MIN.	MAX.	MIN.	MAX.	
f_{SCL}	SCL clock frequency		0	100	0	400	kHz
t_{BUF}	bus free time between a STOP and START condition		4.7	–	1.3	–	μ s
$t_{HD;STA}$	hold time (repeated) START condition; after this period, the first clock pulse is generated		4.0	–	0.6	–	μ s
t_{LOW}	SCL LOW period		4.7	–	1.3	–	μ s
t_{HIGH}	SCL HIGH period		4.0	–	0.6	–	μ s
$t_{SU;STA}$	set-up time for a repeated START condition		4.7	–	0.6	–	μ s
$t_{HD;DAT}$	DATA hold time		0	–	0	0.9	μ s
$t_{SU;DAT}$	DATA set-up time		250	–	100	–	ns
t_r	rise time of both SDA and SCL signals	C_b in pF	–	1000	$20 + 0.1C_b$	300	ns
t_f	fall time of both SDA and SCL signals	C_b in pF	–	300	$20 + 0.1C_b$	300	ns
$t_{SU;STO}$	set-up time for STOP condition		4.0	–	0.6	–	μ s
C_b	capacitive load for each bus line		–	400	–	400	pF
t_{SP}	pulse width of spikes to be suppressed by input filter		not applicable		0	50	ns

Digital Signal Processor

SAA7715AH

16 APPLICATION DIAGRAM

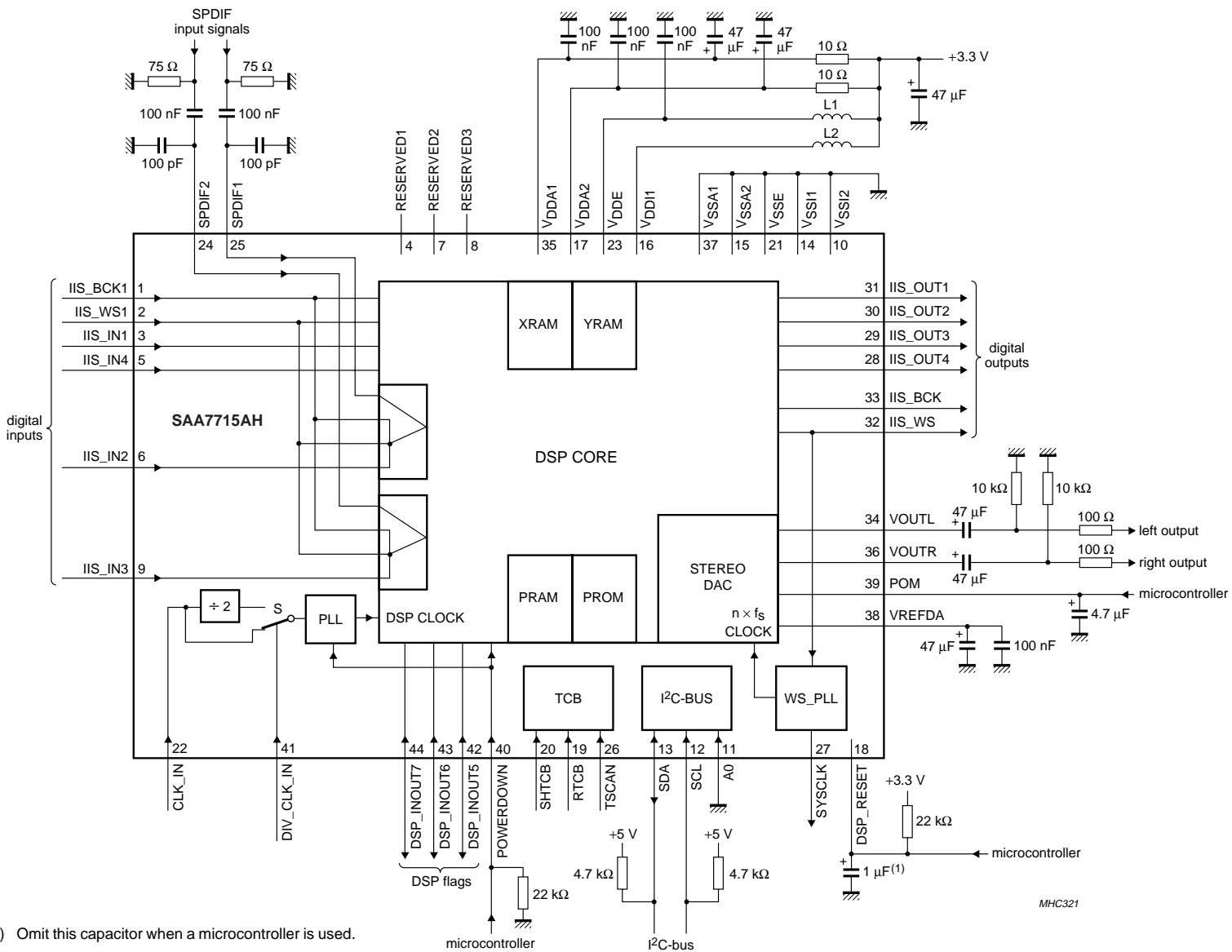

Fig.9 Application diagram.

MHC321

Digital Signal Processor

SAA7715AH

17 PACKAGE OUTLINE

QFP44: plastic quad flat package; 44 leads (lead length 1.3 mm); body 10 x 10 x 1.75 mm

SOT307-2

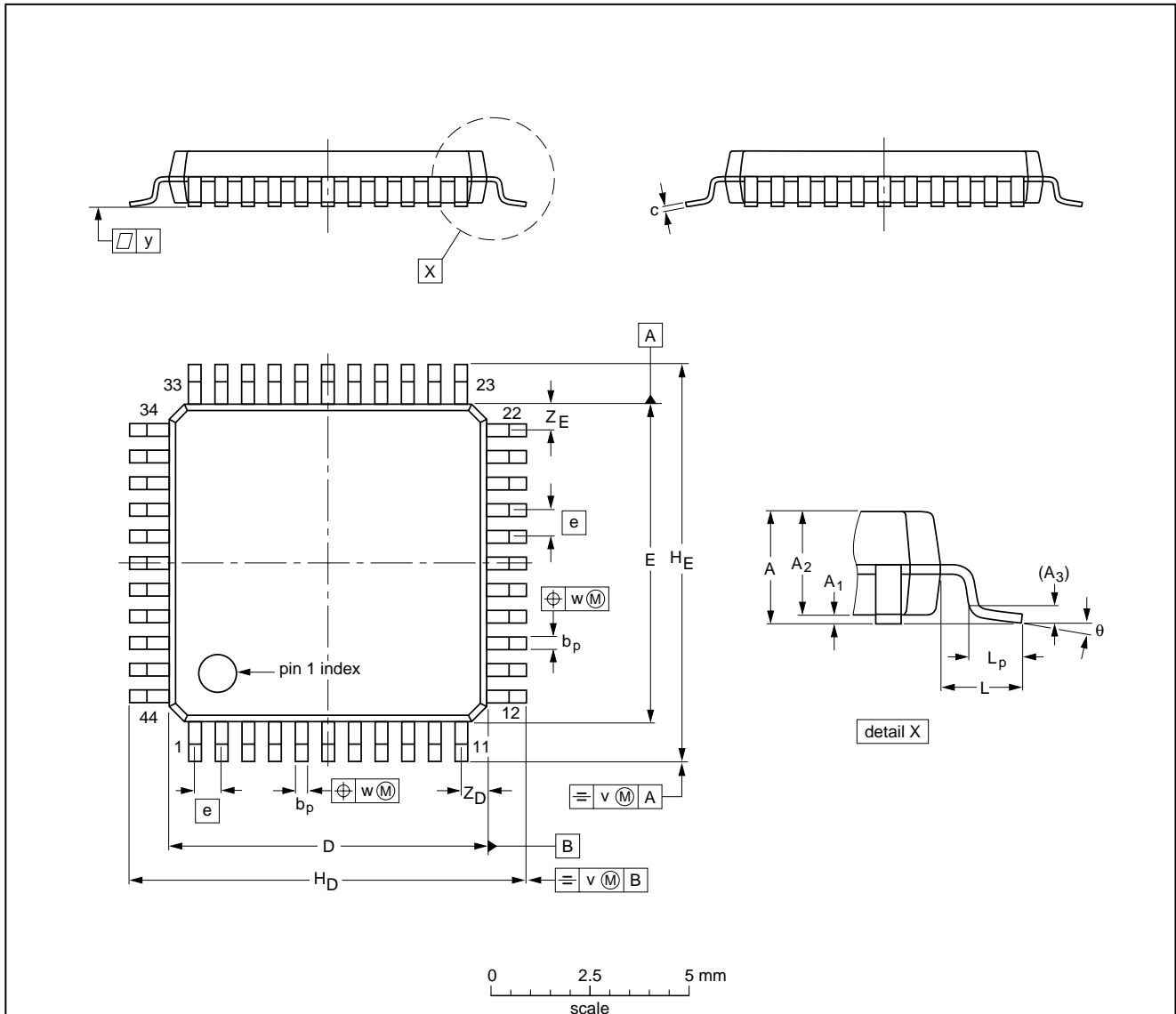

DIMENSIONS (mm are the original dimensions)

UNIT	A max.	A ₁	A ₂	A ₃	b _p	c	D ⁽¹⁾	E ⁽¹⁾	e	H _D	H _E	L	L _p	v	w	y	Z _D ⁽¹⁾	Z _E ⁽¹⁾	θ
mm	2.1	0.25 0.05	1.85 1.65	0.25	0.4 0.2	0.25 0.14	10.1 9.9	10.1 9.9	0.8	12.9 12.3	12.9 12.3	1.3	0.95 0.55	0.15	0.15	0.1	1.2 0.8	1.2 0.8	10° 0°

Note

1. Plastic or metal protrusions of 0.25 mm maximum per side are not included.

OUTLINE VERSION	REFERENCES				EUROPEAN PROJECTION	ISSUE DATE
	IEC	JEDEC	JEITA			
SOT307-2						97-08-01 03-02-25

Digital Signal Processor

SAA7715AH

18 SOLDERING

18.1 Introduction to soldering surface mount packages

This text gives a very brief insight to a complex technology. A more in-depth account of soldering ICs can be found in our *"Data Handbook IC26; Integrated Circuit Packages"* (document order number 9398 652 90011).

There is no soldering method that is ideal for all surface mount IC packages. Wave soldering can still be used for certain surface mount ICs, but it is not suitable for fine pitch SMDs. In these situations reflow soldering is recommended.

18.2 Reflow soldering

Reflow soldering requires solder paste (a suspension of fine solder particles, flux and binding agent) to be applied to the printed-circuit board by screen printing, stencilling or pressure-syringe dispensing before package placement.

Several methods exist for reflowing; for example, convection or convection/infrared heating in a conveyor type oven. Throughput times (preheating, soldering and cooling) vary between 100 and 200 seconds depending on heating method.

Typical reflow peak temperatures range from 215 to 250 °C. The top-surface temperature of the packages should preferably be kept below 220 °C for thick/large packages, and below 235 °C for small/thin packages.

18.3 Wave soldering

Conventional single wave soldering is not recommended for surface mount devices (SMDs) or printed-circuit boards with a high component density, as solder bridging and non-wetting can present major problems.

To overcome these problems the double-wave soldering method was specifically developed.

If wave soldering is used the following conditions must be observed for optimal results:

- Use a double-wave soldering method comprising a turbulent wave with high upward pressure followed by a smooth laminar wave.
- For packages with leads on two sides and a pitch (e):
 - larger than or equal to 1.27 mm, the footprint longitudinal axis is **preferred** to be parallel to the transport direction of the printed-circuit board;
 - smaller than 1.27 mm, the footprint longitudinal axis **must** be parallel to the transport direction of the printed-circuit board.

The footprint must incorporate solder thieves at the downstream end.

- For packages with leads on four sides, the footprint must be placed at a 45° angle to the transport direction of the printed-circuit board. The footprint must incorporate solder thieves downstream and at the side corners.

During placement and before soldering, the package must be fixed with a droplet of adhesive. The adhesive can be applied by screen printing, pin transfer or syringe dispensing. The package can be soldered after the adhesive is cured.

Typical dwell time is 4 seconds at 250 °C.

A mildly-activated flux will eliminate the need for removal of corrosive residues in most applications.

18.4 Manual soldering

Fix the component by first soldering two diagonally-opposite end leads. Use a low voltage (24 V or less) soldering iron applied to the flat part of the lead. Contact time must be limited to 10 seconds at up to 300 °C.

When using a dedicated tool, all other leads can be soldered in one operation within 2 to 5 seconds between 270 and 320 °C.

Digital Signal Processor

SAA7715AH

18.5 Suitability of surface mount IC packages for wave and reflow soldering methods

PACKAGE ⁽¹⁾	SOLDERING METHOD	
	WAVE	REFLOW ⁽²⁾
BGA, LBGA, LFBGA, SQFP, TFBGA, VFBGA	not suitable	suitable
HBCC, HBGA, HLQFP, HSQFP, HSOP, HTQFP, HTSSOP, HVQFN, HVSON, SMS	not suitable ⁽³⁾	suitable
PLCC ⁽⁴⁾ , SO, SOJ	suitable	suitable
LQFP, QFP, TQFP	not recommended ⁽⁴⁾⁽⁵⁾	suitable
SSOP, TSSOP, VSO	not recommended ⁽⁶⁾	suitable

Notes

- For more detailed information on the BGA packages refer to the "*(LF)BGA Application Note*" (AN01026); order a copy from your Philips Semiconductors sales office.
- All surface mount (SMD) packages are moisture sensitive. Depending upon the moisture content, the maximum temperature (with respect to time) and body size of the package, there is a risk that internal or external package cracks may occur due to vaporization of the moisture in them (the so called popcorn effect). For details, refer to the Drypack information in the "*Data Handbook IC26; Integrated Circuit Packages; Section: Packing Methods*".
- These packages are not suitable for wave soldering. On versions with the heatsink on the bottom side, the solder cannot penetrate between the printed-circuit board and the heatsink. On versions with the heatsink on the top side, the solder might be deposited on the heatsink surface.
- If wave soldering is considered, then the package must be placed at a 45° angle to the solder wave direction. The package footprint must incorporate solder thieves downstream and at the side corners.
- Wave soldering is suitable for LQFP, TQFP and QFP packages with a pitch (e) larger than 0.8 mm; it is definitely not suitable for packages with a pitch (e) equal to or smaller than 0.65 mm.
- Wave soldering is suitable for SSOP and TSSOP packages with a pitch (e) equal to or larger than 0.65 mm; it is definitely not suitable for packages with a pitch (e) equal to or smaller than 0.5 mm.

Digital Signal Processor

SAA7715AH

19 DATA SHEET STATUS

DATA SHEET STATUS ⁽¹⁾	PRODUCT STATUS ⁽²⁾	DEFINITIONS
Objective data	Development	This data sheet contains data from the objective specification for product development. Philips Semiconductors reserves the right to change the specification in any manner without notice.
Preliminary data	Qualification	This data sheet contains data from the preliminary specification. Supplementary data will be published at a later date. Philips Semiconductors reserves the right to change the specification without notice, in order to improve the design and supply the best possible product.
Product data	Production	This data sheet contains data from the product specification. Philips Semiconductors reserves the right to make changes at any time in order to improve the design, manufacturing and supply. Changes will be communicated according to the Customer Product/Process Change Notification (CPCN) procedure SNW-SQ-650A.

Notes

1. Please consult the most recently issued data sheet before initiating or completing a design.
2. The product status of the device(s) described in this data sheet may have changed since this data sheet was published. The latest information is available on the Internet at URL <http://www.semiconductors.philips.com>.

20 DEFINITIONS

Short-form specification — The data in a short-form specification is extracted from a full data sheet with the same type number and title. For detailed information see the relevant data sheet or data handbook.

Limiting values definition — Limiting values given are in accordance with the Absolute Maximum Rating System (IEC 60134). Stress above one or more of the limiting values may cause permanent damage to the device. These are stress ratings only and operation of the device at these or at any other conditions above those given in the Characteristics sections of the specification is not implied. Exposure to limiting values for extended periods may affect device reliability.

Application information — Applications that are described herein for any of these products are for illustrative purposes only. Philips Semiconductors make no representation or warranty that such applications will be suitable for the specified use without further testing or modification.

21 DISCLAIMERS

Life support applications — These products are not designed for use in life support appliances, devices, or systems where malfunction of these products can reasonably be expected to result in personal injury. Philips Semiconductors customers using or selling these products for use in such applications do so at their own risk and agree to fully indemnify Philips Semiconductors for any damages resulting from such application.

Right to make changes — Philips Semiconductors reserves the right to make changes, without notice, in the products, including circuits, standard cells, and/or software, described or contained herein in order to improve design and/or performance. Philips Semiconductors assumes no responsibility or liability for the use of any of these products, conveys no licence or title under any patent, copyright, or mask work right to these products, and makes no representations or warranties that these products are free from patent, copyright, or mask work right infringement, unless otherwise specified.

Digital Signal Processor**SAA7715AH**

22 PURCHASE OF PHILIPS I²C COMPONENTS

Purchase of Philips I²C components conveys a license under the Philips' I²C patent to use the components in the I²C system provided the system conforms to the I²C specification defined by Philips. This specification can be ordered using the code 9398 393 40011.

Digital Signal Processor

SAA7715AH

NOTES

Digital Signal Processor

SAA7715AH

NOTES

Digital Signal Processor

SAA7715AH

NOTES

Philips Semiconductors – a worldwide company

Contact information

For additional information please visit <http://www.semiconductors.philips.com>. Fax: +31 40 27 24825

For sales offices addresses send e-mail to: sales.addresses@www.semiconductors.philips.com.

© Koninklijke Philips Electronics N.V. 2003

SCA75

All rights are reserved. Reproduction in whole or in part is prohibited without the prior written consent of the copyright owner.

The information presented in this document does not form part of any quotation or contract, is believed to be accurate and reliable and may be changed without notice. No liability will be accepted by the publisher for any consequence of its use. Publication thereof does not convey nor imply any license under patent- or other industrial or intellectual property rights.

Printed in The Netherlands

753503/01/pp36

Date of release: 2003 Mar 13

Document order number: 9397 750 10206

Let's make things better.

**Philips
Semiconductors**



PHILIPS